

## 刮板输送链 Scraper conveyor chain

刮板输送链 Scraper conveyor chain

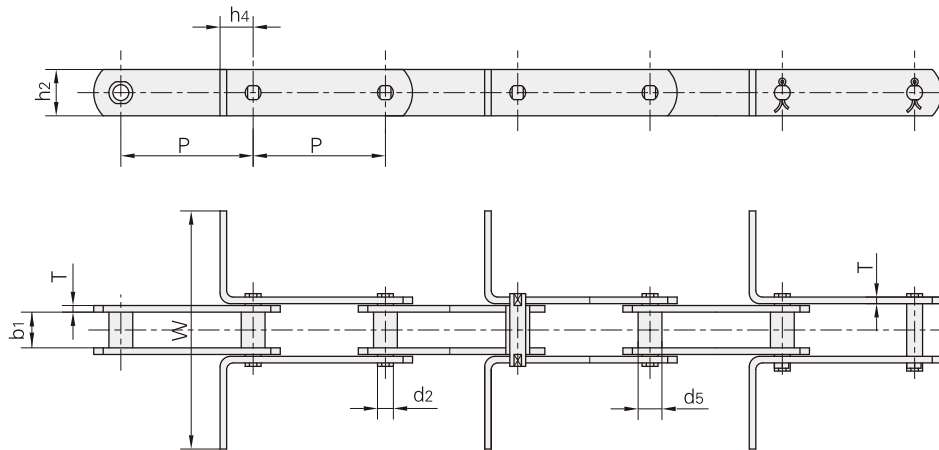

链号 Bison	节距 Pitch		内节内宽 Width between inner plates	销轴直径 Pin diameter	套筒直径 Bush diameter	$h_4$	链板高度 Plate depth	链板厚度 Plate thickness	W	破断载荷 Breaking load	
Bison Chain No.	P		$b_1$ min	$d_2$ max	$d_5$ max	$h_4$	$h_2$ max	T max	mm	Q min	
	mm		mm	mm	mm	mm	mm	mm	mm	mm	
MR56	100	125	-	24.0	10.0	15.0	20.0	30.0	4.0	•	56.0/12727
MR80	100	125	160	28.0	12.0	18.0	25.0	35.0	5.0	•	80.0/18182
MR112	100	125	160	32.0	15.0	21.0	35.0	40.0	6.0	•	112.0/25454
MR160	100	125	160	37.0	18.0	25.0	40.0	50.0	7.0	•	160.0/36364
MR224	125	160	200	43.0	21.0	30.0	44.0	60.0	8.0	•	224.0/50909
MR315	160	200	250	48.0	25.0	36.0	50.0	70.0	10.0	•	315.0/71591
FVR40	80	100	125	18.0	10.0	15.0	20.0	25.0	3.0	•	42.0/9545
FVR63	100	125	160	22.0	12.0	18.0	25.0	30.0	4.0	•	64.0/14545
FVR90	100	125	160	25.0	14.0	20.0	30.0	35.0	5.0	•	100.0/22727
FVR112	100	125	160	30.0	16.0	22.0	35.0	40.0	6.0	•	120.0/27272
FVR140	125	160	200	35.0	18.0	26.0	38.0	45.0	6.0	•	145.0/32954
FVR180	125	160	200	45.0	20.0	30.0	44.0	50.0	8.0	•	190.0/43181
FVR250	160	200	250	55.0	26.0	36.0	50.0	60.0	8.0	•	275.0/62499

•表示自由尺寸(根据客户要求定)

•Dimensions are specified by the customer