

FVT系列输送链 Conveyor chain (FVT series)

FVT系列输送链 Conveyor chain (FVT series)

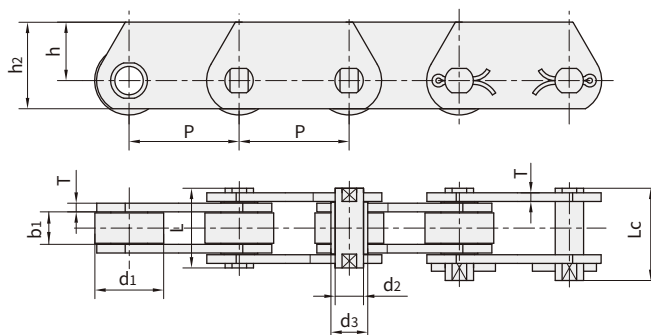

链号 DIN	节距 Pitch								滚子直径 Roller diameter	销轴直径 Pin diameter	套筒直径 Roller diameter	链板厚度 Plate thickness
DIN Chain No.	P								d_1 max	d_2 max	d_3 max	T max
	mm								mm	mm	mm	mm
FVT40	50.0	63.0	80.0	100.0	125.0	-	-	32.0	10.0	15.0	3.0	
FVT63	63.0	80.0	100.0	125.0	160.0	-	-	40.0	12.0	18.0	4.0	
FVT90	63.0	80.0	100.0	125.0	160.0	200.0	250.0	48.0	14.0	20.0	5.0	
FVT112	100.0	125.0	160.0	200.0	250.0	-	-	55.0	16.0	22.0	6.0	
FVT140	100.0	125.0	160.0	200.0	250.0	-	-	60.0	18.0	25.0	6.0	
FVT180	125.0	160.0	200.0	250.0	315.0	-	-	70.0	20.0	30.0	8.0	
FVT250	160.0	200.0	250.0	315.0	-	-	-	80.0	26.0	36.0	8.0	
FVT315	160.0	200.0	250.0	315.0	400.0	-	-	90.0	30.0	42.0	10.0	

FVT系列输送链 Conveyor chain (FVT series)

链号 DIN	内节内宽 Width between inner plates	销轴长度 Pin length		链板高度 Plate depth		极限拉伸载荷 Ultimate tensile strength	
DIN Chain No.	b_1 min	L max	L_c max	h_2 max	h max	Q min	* Q min
	mm	mm	mm	mm	mm	kN/lbf	kN/lbf
FVT40	18.0	36.0	39.0	35.0	22.5	40.0/9091	47.0/10681
FVT63	22.0	45.0	48.5	40.0	25.0	63.0/14317	75.0/17045
FVT90	25.0	53.0	56.5	45.0	27.5	90.0/20453	115.0/26136
FVT112	30.0	62.0	66.0	50.0	30.0	112.0/25452	170.0/38636
FVT140	35.0	67.0	71.5	60.0	37.5	140.0/31815	180.0/40908
FVT180	45.0	86.0	92.0	70.0	45.0	180.0/40908	250.0/56817
FVT250	55.0	97.0	103.5	80.0	50.0	250.0/56817	300.0/68181
FVT315	65.0	113.0	126.5	90.0	55.0	315.0/71591	480.0/109089

■*Q 表示热处理后的极限拉伸载荷

■*Q denotes the ultimate tensile strength after hardened